

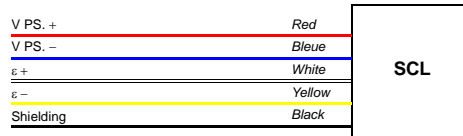

### Description

The measurement principle used in the SCL load cell is based on the deformation of beams to which a compression force is applied. It uses strain gauges arranged to form a Wheatstone bridge for conversion of the force to an electrical signal. The SCL load cell is specially designed to be insensitive to excentric loads while remaining compact.

### Wiring



### Applications

- Weighbridges.
- Weighing of tanks, silos, etc...

### General

The SCL load cell is a compression load cell using single column technology, and is particularly suitable for weighing applications on weighbridges.

The SCL load cell is made of stainless steel and is compact, and is sealed under prolonged immersion (IP 68).

### Options

- Ex version for use in explosive and according to new directive 94/09/ CE.

### Conformity

- Test certificate issued by a notified body in accordance with OIML recommendation R60.

### Available models

- SCL 35t : 1000 d (C1)
- SCL 35t : 3500 d (C3.5) et 2 x 3500 d (C3.5MB)
- SCL 35t : 5000 d (C5) et 2 x 5000 d (C5MB)
- SCL 35t : 7000 d (C7) et 2 x 7000 d (C7MB)
- SCL 35t Ex : 1000 d - C1
- SCL 35t Ex : 3500 d - C3.5
- SCL 35t Ex : 5000 d - C5
- SCL 35t Ex : 7000 d - C7
- SCL 55t : 1000 d (C1)
- SCL 55t : 3500 d (C3.5) et 2 x 3500 d (C3.5MB)
- SCL 55t : 5000 d (C5) et 2 x 5000 d (C5MB)
- SCL 55t : 7000 d (C7) et 2 x 7000 d (C7MB)
- SCL 55t Ex : 1000 d - C1
- SCL 55t Ex : 3500 d - C3.5
- SCL 55t Ex : 5000 d - C5
- SCL 55t Ex : 7000 d - C7



## Dimensions :

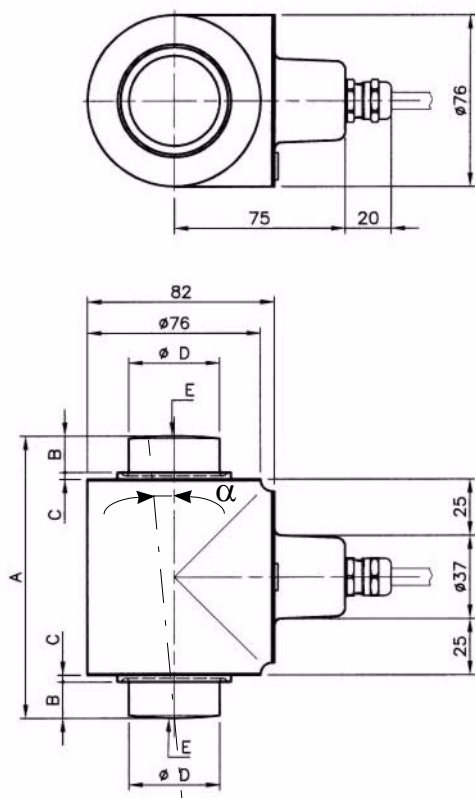

$\alpha$  : Angle d'inclinaison maximum autorisé : ..... 5°.

LOAD CELL	A	F	C	$\varnothing D$	Radius E
SCL-35t	125	16	3	40	175
SCL-55t	153	23	10	48	225

Dimensions in mm and tolerances according to ISO 2768 m, medium accuracy.

## Environmental characteristics

- Temperature range
  - Compensated ..... - 10 °C / + 40 °C
  - Operating ..... - 40 °C / + 80 °C
  - Storage ..... - 40 °C / + 90 °C
- Temperature range - version
  - Compensated ..... - 10 °C / + 40 °C
  - Operating ..... - 20 °C / + 60 °C
  - Storage ..... - 40 °C / + 90 °C
- Sealing and protection according to DIN 40-050.....IP 68

## Mechanical characteristics

- Load limit ..... 150% Emax
- Breaking load..... 300% Emax
- Maximum lateral load ..... 10% Emax

\* The "output ratio" is defined as being the quotient of the "output signal" by the "output impedance".

## Metrological characteristics

Accuracy class*		C3.5	C3.5MB	C1	C5MB	C7MB
Maximum range (E <sub>max</sub> )	t	35/55 t	35/55 t	35/55 t	35/55 t	35/55 t
Verification interval (v min)	kg	E <sub>max</sub> /11666	E <sub>max</sub> /23333	E <sub>max</sub> /5000	E <sub>max</sub> /23333	E <sub>max</sub> /23333
Minimum usage range (E <sub>min</sub> )	% E <sub>max</sub>	0	0	0	0	0

\* The accuracy class option MB are conform with international recommendation OIML R60, for multi-range applications.

## Electrical characteristics

- AC or DC power supply voltage ..... 5 à 20V
- Input impedance..... 1 200  $\Omega$   $\pm$  60  $\Omega$
- Output impedance ..... 1 000  $\Omega$   $\pm$  10  $\Omega$
- Insulation ..... > 5000 M $\Omega$
- Sensitivity (S) ..... 2 mV/V  $\pm$ 1%
- Tolerance on the output ratio %S\* .....  $\leq \pm 0,05$  % S
- Zero unbalance .....  $\leq \pm 1$  % S

Combined error\* %S  $\leq 0,0180$   $\leq 0,0130$   $\leq 0,0180$   $\leq 0,0130$   $\leq 0,0130$

Fidelity error %S  $\leq 0,0100$   $\leq 0,0100$   $\leq 0,0100$   $\leq 0,0100$   $\leq 0,0100$

Temperature effect on sensitivity %S/°C  $\leq 0,0007$   $\leq 0,0007$   $\leq 0,0007$   $\leq 0,0007$   $\leq 0,0007$

Effect of temperature on the signal at minimum dead load. %S/°C  $\leq 0,0012$   $\leq 0,0006$   $\leq 0,0012$   $\leq 0,0006$   $\leq 0,0006$

Return of the output signal at minimum dead load. %S  $\leq 0,0140$   $\leq 0,0070$   $\leq 0,0140$   $\leq 0,0070$   $\leq 0,0070$

Creep (30 minutes) %S  $\leq 0,0140$   $\leq 0,0140$   $\leq 0,0140$   $\leq 0,0140$   $\leq 0,0140$

\* The effect of temperature on the sensitivity and the "combined error" are balanced so that the sum is less than 70% of the error limit for non-automatic weighing instruments in accordance with the OIML R76 international recommendation. The combined error is defined as being the algebraic sum "non-linearity" and "hysteresis".

- Shielded cable with black PVC jacket :
  - Outside  $\varnothing$  ..... 8 mm
  - Length ..... 15 m
  - Maximum radius of curvature. .... 40 mm

Your weighing specialist

Illustrations are not contractual. Precia-Molen reserves the right to modify at any time, without prior notice, the information contained in this leaflet.

Offices and Factory  
 P.O. Box 106 - F 07000 Privas - France  
 Tel. 33 (0) 475 664 600  
 Fax 33 (0) 475 658 330  
 E-MAIL webmaster@preciamolen.com

RCS : 386 620 165 RCS Aubenas

**PRECIA  
 MOLEN™**